

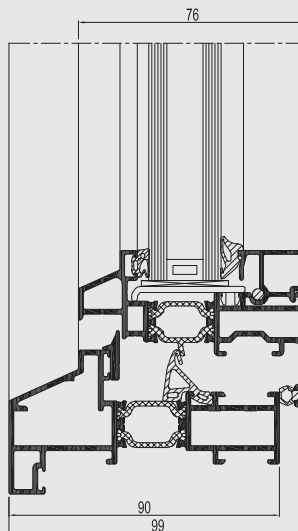

CS 38-SL

Respect for the original

R
REYNAERS
aluminium

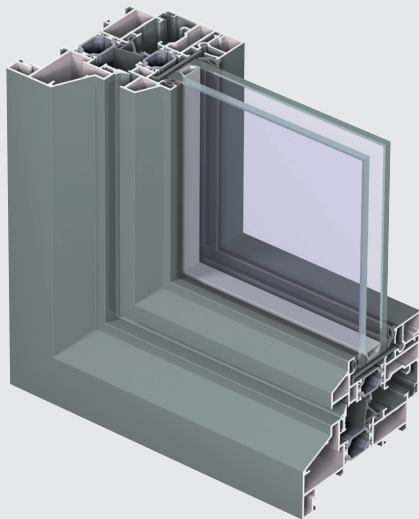

Concept System® 38-SL is a thermally insulated system for inward and outward opening windows and doors that combines elegant design, stability and ease in production. The system's austere style and slender contours on the outside give it a steel look & feel.

As such, CS 38-SL is the perfect solution for both new-build constructions and the replacement of steel-framed windows, respecting the original design but offering a thermally improved solution. The minimalist design is reinforced by an invisible drainage system, avoiding the use of drainage caps on the outside of the windows.

The CS 38-SL is available as single and double entrance doors. Combined with a reduced threshold, the CS 38-SL doors provide a comfortable solution with high levels of water- and air tightness.







CS 38-SL



TECHNICAL CHARACTERISTICS

Style variants		CS 38-SL	CS 38-SL FLAT
Min. visible width inward opening window	Frame	33 mm	48 mm
	Vent	23 mm	22 mm
Min. visible width outward opening window	Frame	29 mm	-
	Vent	60 mm	-
Min. visible width inward opening window-door	Frame	33 mm	-
	Vent	53 mm	-
Min. visible width outward opening window-door	Frame	29 mm	-
	Vent	82 mm	-
Min. visible width T-profile		48 mm	48 mm
Overall system depth window	Frame	90 mm	67 mm
	Vent	76 mm	64 mm
Rebate height		14 mm	14 mm
Glass thickness		up to 44 mm	up to 44 mm
Glazing method		dry glazing with EPDM or neutral silicones	
Thermal insulation		omega-shaped fibreglass reinforced polyamide strips (frame 23 mm - vent 22 mm)	
High Insulation variant (HI)		available	available

PERFORMANCES

ENERGY												
	Thermal Insulation ⁽¹⁾ EN ISO 10077-2	Uf-value down to 2.1 W/m ² K depending on the frame/vent combination and the glass thickness. Uw of less than 1.6 W/m ² K for a standard window section ⁽²⁾										
COMFORT												
	Acoustic performance ⁽³⁾ EN ISO 140-3; EN ISO 717-1	Rw (C; Ctr) = 36 (-1; -4) dB / 45 (0; -3) dB, depending on glazing type										
	Air tightness, max. test pressure ⁽⁴⁾ EN 1026; EN 12207	1 (150 Pa)		2 (300 Pa)			3 (600 Pa)			4 (600 Pa)		
	Water tightness ⁽⁵⁾ EN 1027; EN 12208	1A (0 Pa)	2A (50 Pa)	3A (100 Pa)	4A (150 Pa)	5A (200 Pa)	6A (250 Pa)	7A (300 Pa)	8A (450 Pa)	9A (600 Pa)	E (1200 Pa)	
	Wind load resistance, max. test pressure ⁽⁶⁾ EN 12211; EN 12210	1 (400 Pa)		2 (800 Pa)		3 (1200 Pa)		4 (1600 Pa)		5 (2000 Pa)		E _{xxx} (>2000 Pa)
	Wind load resistance to frame deflection ⁽⁶⁾ EN 12211; EN 12210	A (≤1/150)			B (≤1/200)			C (≤1/300)				

This table shows possible classes and values of performances. The values indicated in red are the ones relevant to this system.

- (1) The Uf-value measures the heat flow. The lower the Uf-value, the better the thermal insulation of the frame.
- (2) Window dimension of 1.23m x 1.48m, with glass of 1.1 W/m²K.
- (3) The sound reduction index (Rw) measures the capacity of the sound reduction performance of the frame.
- (4) The air tightness test measures the volume of air that would pass through a closed window at a certain air pressure.
- (5) The water tightness testing involves applying a uniform water spray at increasing air pressure until water penetrates the window.
- (6) The wind load resistance is a measure of the profile's structural strength and is tested by applying increasing levels of air pressure to simulate the wind force. There are up to five levels of wind resistance (1 to 5) and three deflection classes (A,B,C). The higher the number, the better the performance.

